

SBS-Control Operating Instructions BKS24-9A

Table of contents

Operating Instructions

1 Operating controls and indicators	2
2 Preparations for faultless commissioning and operating	3
3 Programming the number of dampers per BKS24-9A	4
4 Adding / removing of dampers	5
5 System testing	6
6 Function testing	7
7 Fault alarms	8

Technical data	9
-----------------------	----------

1 Operating controls and indicators

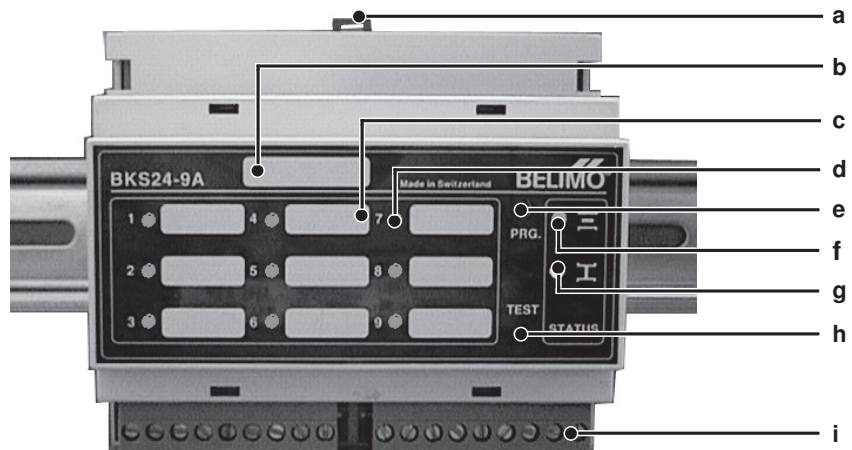

a	Retaining-Clip	Lift clip with Screwdriver for mounting-/removing
b	Label	For zone identification
c	Label 1 ... 9	For damper identification
d	LEDs (red) FAULT dampers 1 ... 9	Off = No alarm Flashing = Alarm present On = Alarm stored
e	Pushbutton PRG. (This pushbutton is recessed, use a proper tool to operate).	– Programming the number of dampers – Check the number of dampers
f	LED (green) NORMAL Position	Flashing = Dampers run to NORMAL Position (OPEN) On = Dampers have reached NORMAL Position
g	LED (yellow) SAFE Position	Flashing = Dampers run to SAFE Position (CLOSE) On = Dampers have reached SAFE Position
h	Pushbutton TEST	– System Test (Dampers/Actuators/Control Unit) – Functional Test (for checking the system manually)
i	Electrical connection	9-Pin Terminal Connectors

2 Preparations for faultless commissioning and operating

2.1

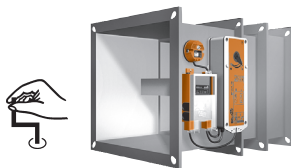

- Fire dampers are installed and mechanically tested
- **OPEN** and **CLOSED** end positions attainable

2.2



- Fire damper actuators (AC 24 V) connected (both cables) to the BKN230-24 or BKN230-24-C-MP units

2.3



- Terminals 1 to 7 of the BKN230-24 or BKN230-24-C-MP unit correctly wired according to the wiring diagram and technical documentation
- Ensure correct polarity when connecting the 2-wire conductors (terminals 6 and 7)

2.4

AC 230 V



- All BKN230-24 and BKN230-24-C-MP units connected to the AC 230 V power supply (by mains connector or terminal box)

2.5

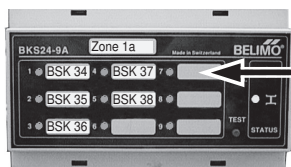

- Number and sequence of connected dampers labelled and programmed (e.g.1 ... 5) on the front of the BKS24-9A unit
- Programming see Para. 3

2.6

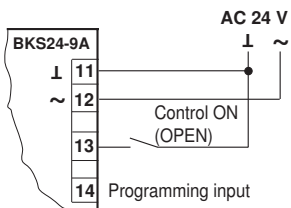

- **OPEN Command** is present at the BKS24-9A unit causing the dampers to be moved to the operating position

2.7

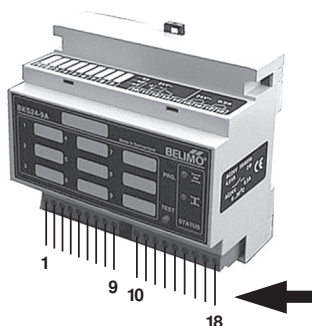

- All other inputs correctly wired according to the wiring diagram and the technical documentation

3 Programming the number of dampers per BKS24-9A

Targets

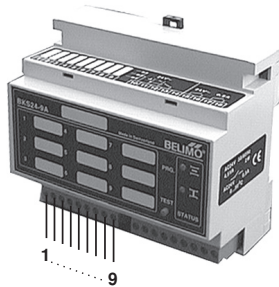

- Factory programmig:
The BKS24-9A unit is factory programmed for **9 dampers**

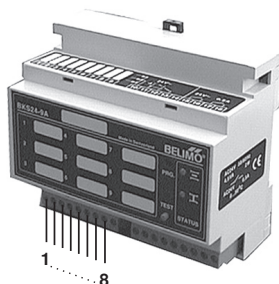

- The programming must be modified accordingly when connecting 1 to 8 dampers

3.1 ... 3.5 Procedure

3.1 Note preparatory work in Para. 2



3.2

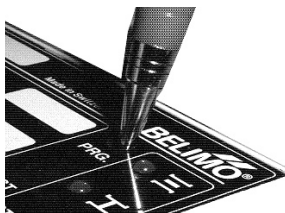

- Press and hold **PRG.** key (until 3.5 included)

3.3



- The fault LEDs for the number of dampers programmed **light up for 4 seconds** (e.g. 1 to 9)

3.4



- The fault LEDs for the number of dampers programmed and acknowledged by the BKS24-9A unit start **flashing** (e.g. 1 to 5)
- The number of dampers acknowledged must correspond to the number of dampers labelled

3.5

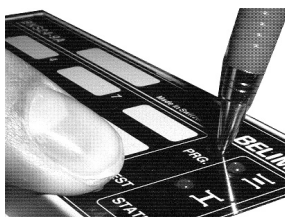

- Press the **TEST** key at the same time as the **PRG.** key
- The number of dampers acknowledged is now programmed in the BKS24-9A unit

Note

A System test is initiated automatically (see Para. 5)

4 Adding / removing of dampers

Example A fire damper is to be added to an existing system, resp. or is being removed.
The dampers 1 to 5 are in operation and damper 6 is the new one, or but, damper 5 is being removed.
The comment in (***bold italics***) refers to the removal of a damper.

4.1 ... 4.5 Procedure

4.1



- Note preparatory work in Para. 2
- An automatic system test is performed when the power supply (AC 24 V) is energised (see Para. 5)
- Start flashing:
 - The status LED for **OPEN** and the fault LED of the **new damper 6**, or
 - *The status LED for OPEN and the fault LED of the removed damper 5*

4.2

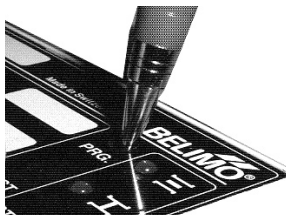

- Label adapting on the front of the BKS24-9A unit
Dampers 1 ... 4 or
Dampers 1 ... 6
- Press and hold the **PRG.** key

4.3



- The fault LED for the five dampers programmed (see example) **light up for 4 Seconds**

4.4



- The fault LEDs for the number of dampers programmed and acknowledged by the BKS24-9A unit start **flashing**
 - after adding a damper actuator the fault LED 1 to 6 start flashing
 - *after removing a damper actuator the fault LED 1 to 4 start flashing*
- The number of dampers acknowledged must correspond to the number of dampers labelled

4.5

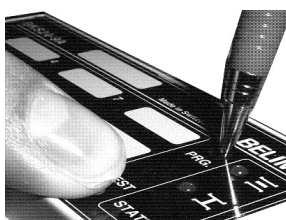

- Press the **TEST** key at the same time as the **PRG.** key
- The number of dampers acknowledged is now programmed in the BKS24-9A unit

Note

A System test is initiated automatically (see Para. 5)

5 System testing



- The system test deals with the connected dampers, the actuators, the installation and the control unit
- Note preparatory work in Para. 2
- The dampers are moved to the **OPEN** and **CLOSED** position during the test

5.1 Initiation criteria

a) Automatic

- After **programming** of connecting
- After **powering up** (AC 24 V)

b) After a fault alarm

- By pressing the **TEST** key

5.2 ... 5.7 Procedure

5.2



- All 11 LEDs **light up for 4 Seconds** (lamptest)

5.3



- The **OPEN/CLOSED** status LEDs **flash alternately** for the duration of the system test

5.4

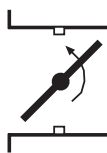

- The dampers are moved in the **CLOSED** direction and must attain the **safe position**

5.5

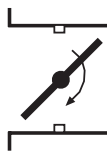

- The dampers are moved in the **OPEN** direction and must attain the **operating position** (as described in Para. 2.6)

5.6



- The status LED for **OPEN** starts **flashing** when the damper departs from the safe position
- The status LED for **OPEN** gives a **steady light** when the damper reaches the operating position

5.7



- The system is now ready to use

6 Function testing



- The purpose of the function test is for checking the system manually
- Note preparatory work in Para. 2
- The connected fire dampers are moved to the **CLOSED** and **OPEN** positions

6.1 Initiation criteria

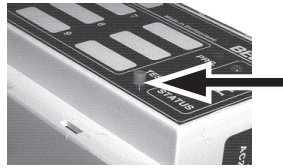

- Press and hold the **TEST** key

6.2 ... 6.6 Procedure

6.2

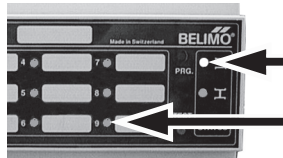

- The status LED for **OPEN** lights up
- All fire dampers are in the operating position (OPEN)
- The fault LEDs 1 to 9 are off

6.3

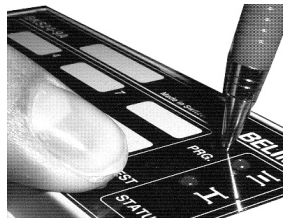

- Press and hold the **TEST** key
- The status LED for **CLOSED** will start **flashing**

6.4

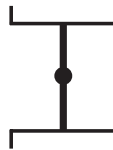

- When the status LED for **CLOSED** gives a **steady light** it means that the dampers have reached the **safe position**
- Release the **TEST** key

6.5



- The dampers move to the **operating** position
- When the status LED for **OPEN** gives a **steady light** it means that the function test has been completed successfully

6.6



- The system is ready for use

7 Fault alarms

7.1 Existing fault



Fault in the system

- Fault LED **flashing** (e.g. damper 4)
- Status LED for **OPEN** or **CLOSED flashing** (depending on control signal)
- ▶ **Existing fault**
- ▶ **Contact K1 open**

Note

Possible causes see Para. 7.3

7.2 Stored fault



Temporary fault in the system

- Fault LED **bright** (e.g. damper 4)
- ▶ **Stored fault**
- ▶ **Contact K1 closed**
- A stored fault can be acknowledged in two ways:
 1. Manually with the **TEST** key (see Para. 4)
 2. Automatically when the dampers have run properly to **two** successive end positions OPEN / CLOSED

7.3 Initiation criteria

- When a fire damper does not reach the operating position or safe position within the specified running time
 - ▶ Para. 2.1
- Open-circuit or wrong polarity on 2-wire conductor
 - ▶ Para. 2.4 to 2.7
- Open-circuit or fault in the Tripping Device BAE72-S
 - ▶ Para. 2.4
- No power supply or fault in the BKN230-24 or BKN230-24-C-MP unit
 - ▶ Para. 2.3
- Open-circuit or fault at the plug connections from damper actuator to the BKN230-24 or BKN230-24-C-MP unit
 - ▶ Para. 2.2
- After adding a damper actuator to or removing one from an existing system
 - ▶ Para. 4

7.4 Unit fault



Fault in the BKS24-9A unit

- All 11 LEDs on the BKS24-9A unit flash in unison
 - ▶ It means that the BKS24-9A unit is defective and must be replaced

Communication and control unit for control and monitoring of up to nine motorized fire dampers in combination with the communication and power supply units BKN230-24 or BKN230-24-C-MP

- Signals the operating positions and any faults from the fire dampers to which it is connected.
- Reduced wiring costs due to 2-wire communication
- Propagation of group alarm and damper position to an overhead system via auxiliary contacts
- Panel mounting (DIN rail)



Technical data

Electrical data	Nominal voltage	AC 24 V, 50/60 Hz	
	Power supply range	AC 21,6 ... 28,8 V	
	Power consumption	In operation	3.5 W
		For wire sizing	5.5 VA (I max. 6.4 A at 2.5 ms)
	Connection	Terminals for 2 x 1.5 mm ²	
	Lengths of conductors	2-wire conductors a/b	max. 600 m (wire 0.75 mm ²)
control input 13		max. 600 m (wire 0.75 mm ²)	
Auxiliary contacts	AC 24 V at 0.5 A		
Safety	Protection class	III safety extra-low voltage / UL Class 2 Supply	
	Degree of protection	IP20	
	EMC	CE according to 2004/108/EG	
	Mode of operation	Type 1 (EN 60730-1)	
	Rated impulse voltage	0.5 kV (EN 60730-1)	
	Control pollution degree	2 (EN 60730-1)	
	Ambient temperature	0 ... +50 °C	
	Non-operating temperature	-30 ... +50 °C	
	Maintenance	Maintenance-free	
	Dimensions / Weight	Dimensions	See «Dimensions» on page 2
Weight		Approx. 160 g	

Safety notes

- The device is not allowed to be used outside the specified field of application, especially in aircraft or in any other airborne means of transport.
- It may only be installed by suitably trained personnel. Any legal regulations or regulations issued by authorities must be observed during assembly.
- The device may only be opened at the manufacturer's site. It does not contain any parts that can be replaced or repaired by the user.
- The device contains electrical and electronic components and is not allowed to be disposed of as household refuse. All locally valid regulations and requirements must be observed.

Product features

Mode of operation	The BKS24-9A unit receives position signals from the BKN230-24 or the BKN230-24-C-MP units and transmits control commands to them over the 2-wire conductors. Correct operation of the dampers is indicated by the 2 LEDs: Control ON = NORMAL Position  Control OFF = SAFE Position 
Fault	If the damper does not reach the required position within the preset time, the appropriate on-board FAULT LED flashes and, at the same time, the FAULT contact K1 is activated. This contact is overridden as soon the defective damper reaches the required position. The on-board FAULT LED remains on, until the fault is reset.
Auxiliary contact K2	An auxiliary contact is provided for signaling the positions of dampers to a higher-level system. The function of the auxiliary contact can be programmed via terminal 14 according to the instructions beside.

Product features

(Continued)

Installation and connections The BKS24-9A unit can be clipped directly onto a 35 mm DIN mounting rail and external wiring is connected by two 9-pin terminal connectors.

Functional testing Functional testing can be performed by pressing the TEST pushbutton. While this button is held depressed, the dampers run to the SAFE position. Any malfunctions are indicated by the internal FAULT LEDs.

Fire zoning The required fire zones must be taken into account when making the groupings and when wiring the BKS24-9A unit.

Electrical installation

Wiring diagram

Notes

- Connect via safety isolation transformer.
- Relay contacts K1 and K2 are shown without power applied.

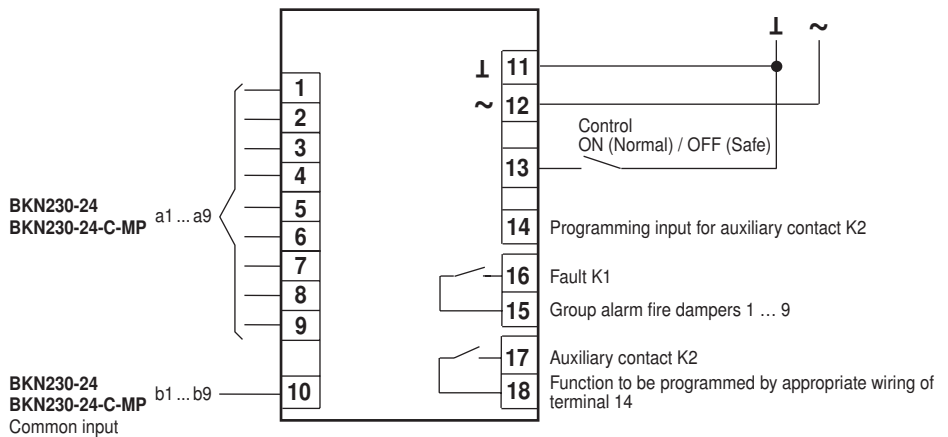

Contact K1 and auxiliary contact K2

Function contact K1	
Situation	Status
Alarm	15 — 16
No alarm	15 — 16

Programming auxiliary contact K2		
Function	Wiring	Status
Contact K2 closed, when all Dampers OPEN	14 — 11 ⊥	17 — 18
Contact K2 closed, when Damper No. 1 OPEN	14 — 12 ~	
Contact K2 closed, when all Dampers CLOSED	14 left open	

Dimensions [mm]

Dimensional drawings

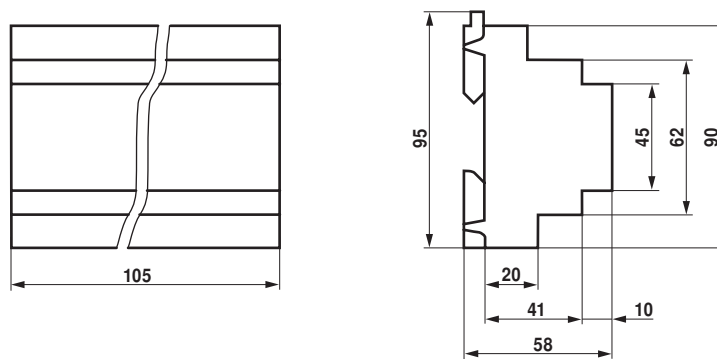

All inclusive.



Headquarters

BELIMO Holding AG
Brunnenbachstrasse 1
CH-8340 Hinwil
Tel. +41 (0)43 843 61 11
Fax +41 (0)43 843 62 68
info@belimo.ch
www.belimo.com

Subsidiaries, Representatives and Agencies

Argentina
Australia
Bahrain
Belgium
Bosnia-Herzegovina
Brazil
Bulgaria
Canada
Chile
Croatia
Cyprus
Czech Republic

Denmark
Egypt
Estonia
Finland
France
Great Britain
Germany
Greece
Hong Kong
Hungary
Iceland
India
Indonesia
Ireland
Israel
Italy
Japan
Jordan
Kuwait
Latvia

Lebanon
Liechtenstein
Lithuania
Luxembourg
Malaysia
Mexico
Morocco
Netherlands
New Zealand
Norway
Oman
Pakistan
People's Republic of China
Philippines
Poland
Portugal
Qatar
Republic of Korea (South Korea)

Rumania
Russia
Saudi Arabia
Singapore
Slovakia
Slovenia
South Africa
Spain
Sweden
Switzerland
Taiwan
Turkey
Ukraine
United Arab Emirates
United States of America